

1	2	3	4	5	6	7	8	
					REV	ZONE	REVISION	DATE

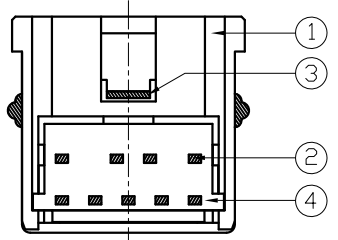
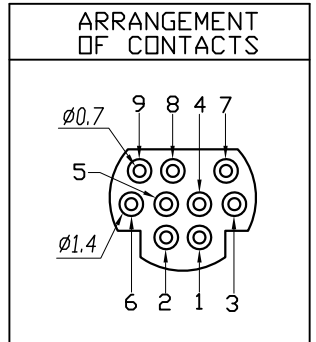
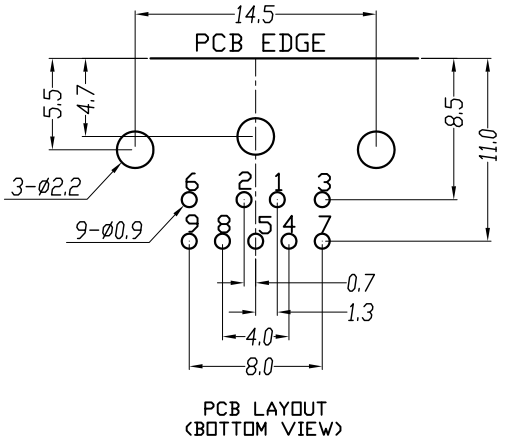
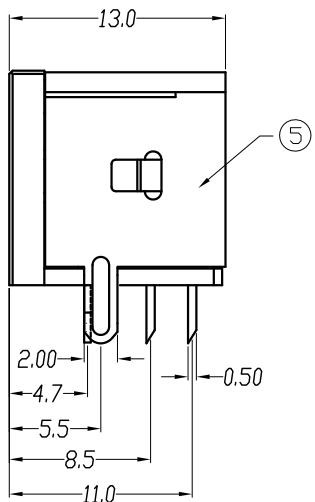
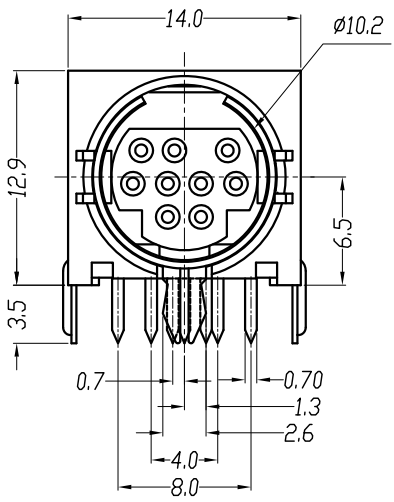

Green Product

Specification:
 Contact Resistance: 30m Ohm Max.
 Insulation Resistance: 100M Ohm Min. AT 500V DC
 Rated Voltage And Current: DC12V.2A Max; AC 100V.1A Max
 Dielectric Withstanding Voltage: 250V AC For 1 Minute
 Durability (Life Test): 100 Cycles
 Insertion Force: 4.0KG Maximum.
 Extraction Force: 0.9KG Minimum.

NO.	NAME	MATERIAL	FINISH	Q'TY	REMARK
1	HOUSING	PBT G.F.	BLACK	1	
2	CONTACT TERM.	PHOS. BRONZE T:0.2	GOLD-TIN PLATED	9	Gold:1~3u"; NI:40~60u"; TIN:120u" (100% pure Tin of lead free plating)
3	GROUND TERM.	BRASS T:0.4	TIN PLATED	1	TIN:120~200u"
4	BOTTOM COVER	PBT G.F.	BLACK	1	
5	SHELL	SPCC, T:0.3	NICKEL PLATED	1	NI:80~120u"



易昕企業有限公司
 LEAMAX ENTERPRISE CO.,LED.

Drawing No			UNIT	SCALE	TITLE		
3262-009			mm	1:1	MINI DIN JACK FLAT 9 PIN DIP		
APPD.	CKD.	DWG.	DATE	TOLERANCE	PART NO.	REV.	
JAMES 23-11-15	SHIRLEY 02-11-15	TINA 29-03-10	29-03-10	X. ±0.38 .X ±0.25 .XX ±0.13 .XXX ±0.05	3262-9E	A0	

MODEL

3262-9E

PAGE 1 OF 1