

REV	ZONE	REVISION	DATE

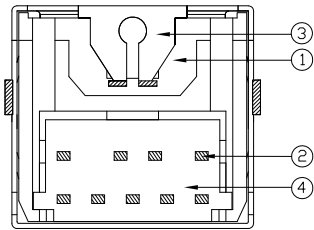
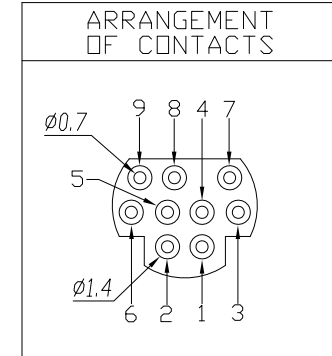
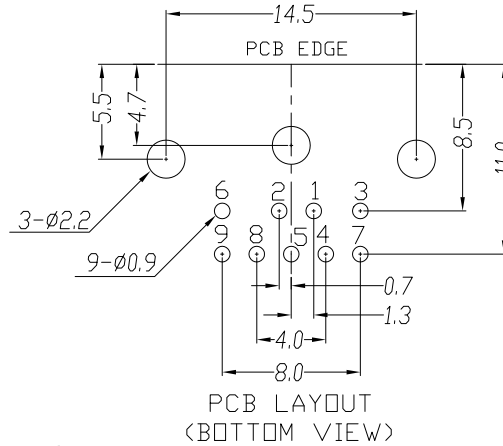
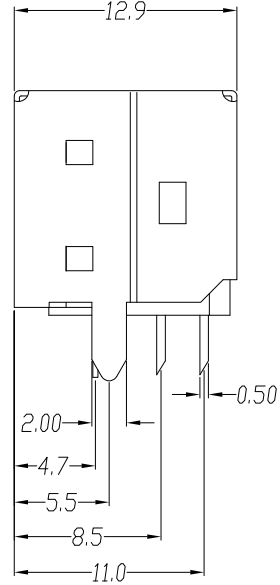
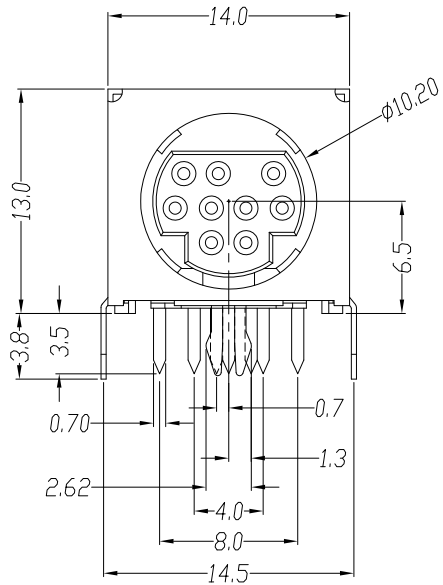

Green Product

Specification:

Contact Resistance: 30m Ohm Max.

Insulation Resistance: 100M Ohm Min. AT 500V DC

Rated Voltage And Current: DC12V.2A Max; AC 100V.1A Max

Dielectric Withstanding Voltage: 250V AC For 1 Minute

Durability (Life Test): 100 Cycles

Insertion Force: 4.0KG Maximum.

Extraction Force: 0.9KG Minimum.

NO.	NAME	MATERIAL	FINISH	Q'TY
1	HOUSING	PBT G.F.	BLACK	1
2	CONTACT	PHOS. BRONZE T:0.2	Gold:1~3u"; NI:40~60u"; TIN:120u" (100% pure Tin of lead free plating)	9
3	SHIELD	BRASS T:0.3	TIN PLATED Sn:120~200u"	1
4	BOTTOM COVER	PBT G.F.	BLACK	1



易昕企業有限公司
LEAMAX ENTERPRISE CO., LED.

Drawing No

3263-009

UNIT

mm

SCALE

1:1

TITLE

MINI DIN JACK FLAT 9 PIN DIP

APPD.

JAMES
17-03-14

CKD.

SHIRLEY
03-03-14

DWG.

TINA
08-04-10

DATE

08-04-10

TOLERANCE

X. ±0.38
.X ±0.25
.XX ±0.13
.XXX ±0.05

PART NO.

3263-9E

REV.

A1

MODEL

3263-9E

PAGE 1 OF 1