

REV	ECO	DESCRIPTION	DRAWN	DATE

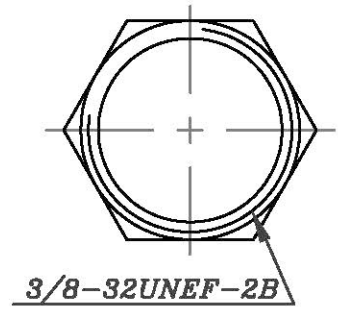

④ LOCK WASHER

⑤ CLAMP NUT

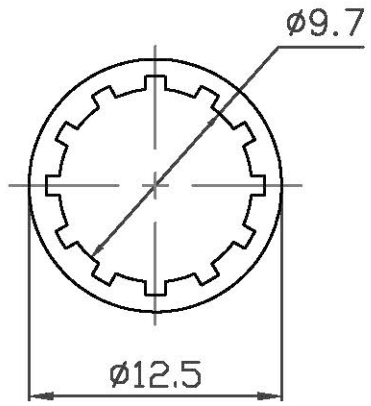
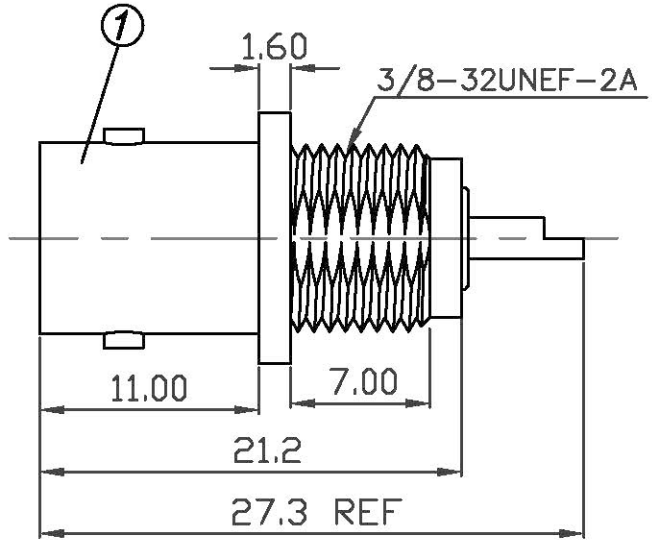
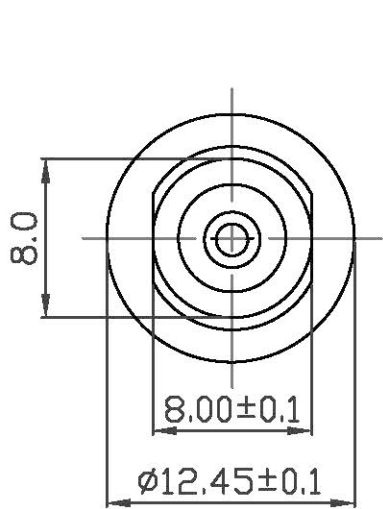
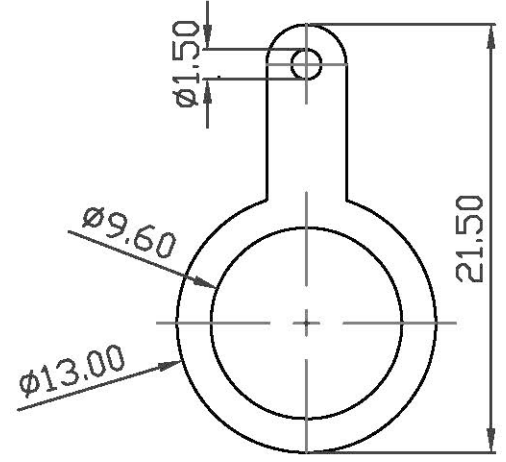
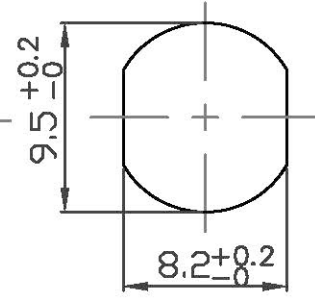
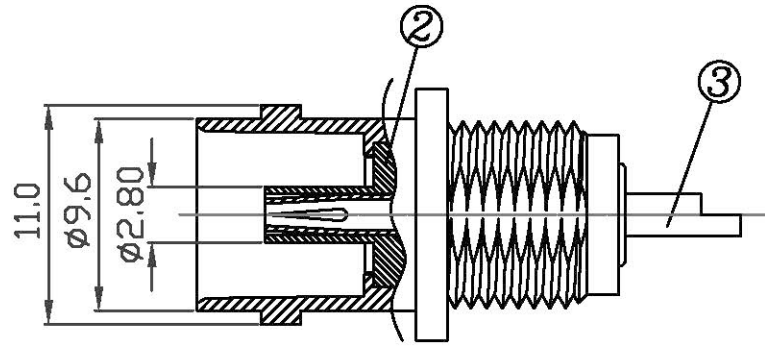

RECOMMENDED MOUNTING HOLE

⑥ SOLDER TAG

MATERIAL & FINISH

- ① BODY : ZINC ALLOY, NICKEL PLATING
- ② DIELECTRIC : POM
- ③ CENTER CONTACT : PHOSPHOR BRONZE, GOLD PLATING
- ④ WASHER : STEEL, NICKEL PLATING
- ⑤ NUT : IRON, NICKEL PLATING
- ⑥ SOLDER TAG: IRON, NICKEL PLATING

PART NUMBER 3291-7BH-2B73-WNS	DWG. Jean_Ke	DATE 15-12-11	易昕企業有限公司 LEAMAX ENTERPRISE CO., LTD.
	CKD. Huang	DATE 02-05-18	
MATERIAL SEE NOTE	APPD. James	DATE 12-05-18	75Ω BNC BULKHEAD RECEPTACLE FRONT MOUNT WITH FITTING
FINISH SEE NOTE	<small>UNLESS OTHERWISE SPECIFIED: DIMENSIONS ARE IN mm TOLERANCES ARE:</small> X. ± 0.5 XX ± 0.3 XXX ± 0.2 ANGLES ± 3 DEG		
THIRD ANGLE PROJECTION	DO NOT SCALE DRAWING		DWG NO. 3291-002
SCALE 2:1		CAD FILE ERP	REV A
SHEET 1 OF 1			