

REV.	ECN NO. / DESCRIPTION	DATE
A	R100409	10-09-10

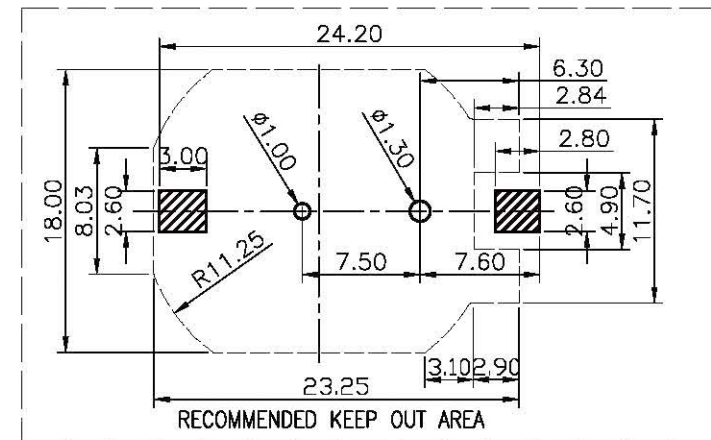

RECOMMENDED PC BOARD LAYOUT

TOLERANCES: ±0.05

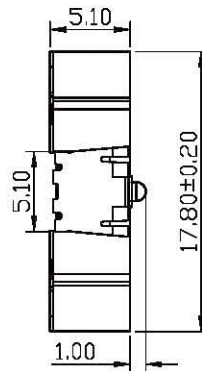
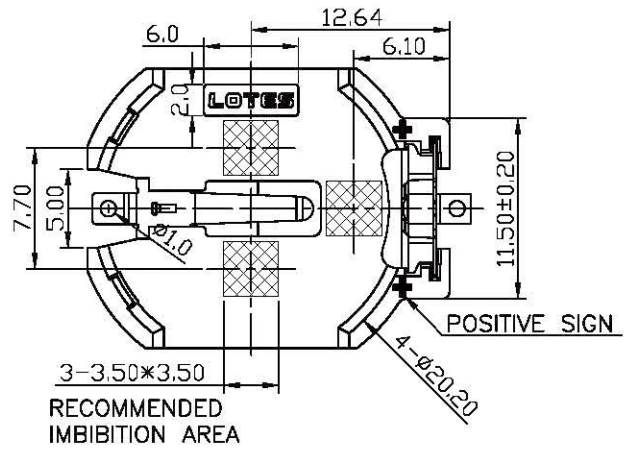
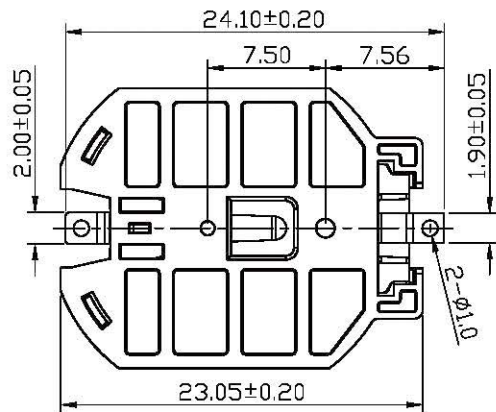
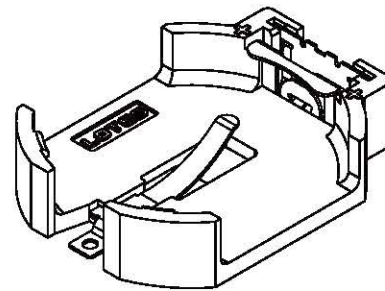
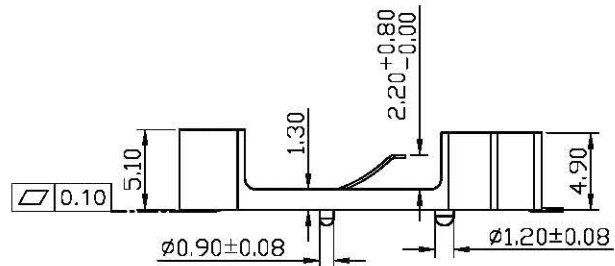

NOTES:

- MATERIAL SPECIFICATION,  
1-1.HOUSING:THERMPLASTIC\_LCP,BLACK.  
1-2.CONTACTS: COPPER AOLLY
- PLATING SPECIFICATION,  
50u"min. NICKEL PLATED OVER ALL,  
AND G/F PLATING ON THE CONTACT AREA .
- HF COMPLIANT,

GENERAL TOLERANCES UNLESS SPECIFIED		PART NO. 4340-HSJ3E	 <b>易昕企業有限公司</b> LEAMAX ENTERPRISE CO., LTD.
X ±0.35	X° ±3°		
XX ±0.25	X° ±2°	APPD James	TITLE BATTERY HOLDER FOR CR2032
XXX ±0.15	XX° ±1°	26-03-14	
CUSTOMER DRAWING		CHD Huang	DWG NO.4340-009
		03-03-14	
SIZE	UNITS	DWG	 SHEET 1/1    SCALE 2:1    REV A
A4	MM[INCH]	Yusheng 10-09-10	